



VGS-WHT-81853S300UF

**SPECIFICATION DATA SHEET**

**PRODUCT DETAILS**

<b>Manufacturer</b>	Jaquar	<b>Type</b>	Single piece-WC (S trap )
<b>Colour</b>	White	<b>Flush valves</b>	Dual Flush
<b>Outlet</b>	Vertical	<b>Material</b>	Ceramic - Vitreous China
<b>Technical Details</b>	External diameter of outlet hole $\varnothing$ 80 mm Horizontal distance between the wall line and the centre line of the waste outlet hole $\leq$ 300 mm		

**PRODUCT IMAGE**



**TECHNICAL DRAWING**

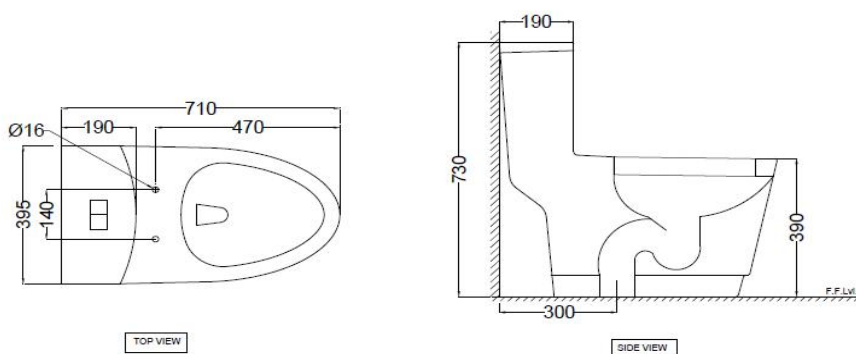

<b>Product Dimension</b>	395x710x730 mm	<b>FEATURES</b>  Rimless bowl design, Siphonic effect, Tornado Flushing, Dual flush 2.6/4.6 LPF,Anti germ glaze.
<b>Trap Distance</b>	S Trap - 300 mm	
<b>Product Weight</b>	44.25 Kg	

**ACCESSORIES INCLUDED**

UF soft Close seat cover	VGS-WHT-81105NUF
Floor fixing screw	ZPS-SNS-FB01
Wax Seal	ZPS-WHT-1401

**CERTIFICATION**

Compliance : EN 997 : 2012+A1:2015 (E), SASO 06-04-16-156.,SS 574:PART-1: 2012, SANS 497:2011

All technical dimensions are in accordance to British standards, Bureau of Indian Standards



DISCLAIMER: Our every effort has been made to ensure factual accuracy, the information presented subject to changes due to requirements in different sites, markets and/ or countries. All dimensions are in mm (Tolerance  $\pm$  5 MM). Jaquar reserves the right to make the necessary amendments at any time without prior notice.